



Scanning Stage SCAN^{plus} 100 × 100 for Upright Microscopes

Specifications

Travel range	max. 100 × 100 mm
Travel speed	max. 120 mm/s (with 2 mm ball screw pitch) max. 240 mm/s (with 4 mm ball screw pitch)
Repeatability	≤ 0.2 μm ¹
Accuracy	±1 μm ²
Resolution	0.05 μm (smallest step size)
Orthogonality	< 10 arcsec
Motor type	2-phase stepper motor
Limit switches	continuously adjustable optical light barriers
Material / surface	aluminium / anodic coating, black laquered
Weight	approx. 4.6 kg

Order Information

Order No.: 00-24-574-0000 (2 mm)
Order No.: 00-24-575-0000 (4 mm)

Product Features

- ▶ integrated linear measuring systems for highest accuracy
- ▶ flat, ergonomic design with rounded corners
- ▶ plain surface for easy cleaning
- ▶ exchangeable stage inserts for different kinds of applications
- ▶ continuously adjustable optical light barriers for individual travel range limitation
- ▶ integrated electronic stage identification device ETS for automatic identification of the scanning stage and parametrization of the controller
- ▶ **5 years guarantee**, if the scanning stage is operated in the system with the Märzhäuser TANGO controller

Dimensions

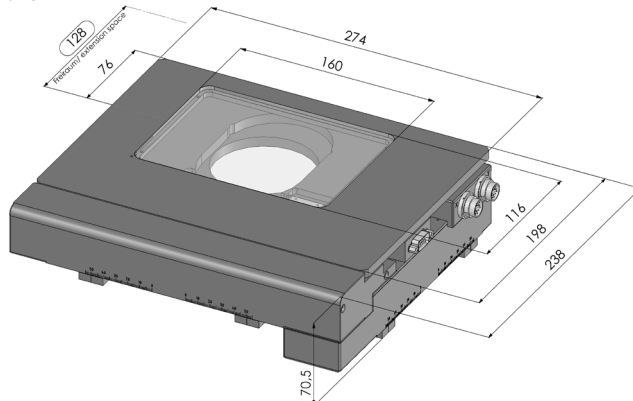

Accessories

Glass plate (included in delivery)
Order No.: 00-24-427-0810

For further accessories please visit:
www.marzhäuser.com